

Data sheet

# Actuators for modulating control

## AME 13 SU/SD-1 - safety function

Description

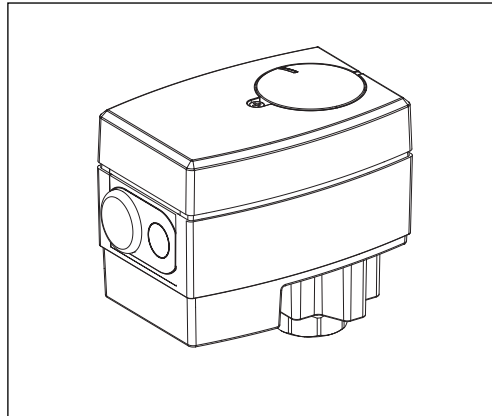

The AME 13 SU/SD-1 is a compact gear motor actuator that is assembled to 1/2" to 1-1/4" AB-QM valves sizes. Safety version is activated automatically in case of power failure or if the power supply is switched off by the safety thermostat.

- The actuator has some special features:
- The advanced design incorporates load related 'switch-off' to ensure that actuators and valves are not exposed to overload
  - The advanced design incorporates a diagnostic LED, operational data capture and self stroking feature
  - Low weight and robust
  - Safety function (spring up / spring down)

**Main data:**

- Nominal voltage:
  - 24 VAC, 50 Hz/60 Hz
- Control input signal:
  - 0(4)...20 mA
  - 0(2) ... 10 V
- Force: 300 N
- Stroke: 5,5 mm
- Speed: 11.75 s/mm (50 Hz) / 14 s/mm (60 Hz)
- Max. medium temperature: 130 °C
- Electronic stroke limitation
- In accordance with UL 2043 for plenum installation

Ordering

Type	Supply voltage	Code No.
AME 13 SU-1	24 V~	<b>082H5006</b>
AME 13 SD-1		<b>082H5007</b>

Technical data

Type		AME 13 SU/SD-1
Power supply	V	24; +10 to -15 %; AC
Power consumption	VA	9
Frequency	Hz	50/60
Control input Y	V	0-10 (2-10)
	mA	0-20 (4-20)
Output signal X	V	0-10 (2-10)
Closing force	lbf (N)	67.4 (300)
Max. stroke	mm	5,5
Speed	s/mm	11.75 (50 Hz) / 14 (60 Hz)
Max. medium temperature		248 (120)
Ambient temperature	°F (°C)	32... + 131 (0... + 55)
Storage and transport temp.		-40...+158 (-40...+70)
Grade of enclosure		IP 54
Ambient humidity		95% r.h., non-condensing
Protection class		Class 2 (North America) or Safety Extra-Low Voltage (SELV) (Europe)
Weight	lbs (kg)	1.76 (0.8)

	USA	UL Listed, CCN XABE, File E480529; to ANSI/UL 60730-1 and ANSI/UL 60730-2-14 Investigated and approved for plenum use in accordance with UL 2043
	Canada	UL listed, CCN XABE7, File E480529; to CAN/CSA-E60730-1:13 and CAN/CSA-E60730-2-14:13
	Europe	CE Mark - Danfoss declares that this product complies with all relevant CE-marking directives

Installation

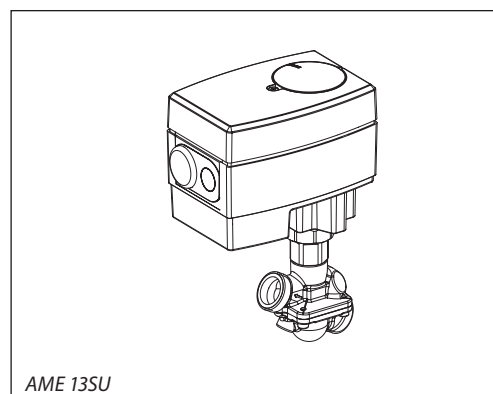
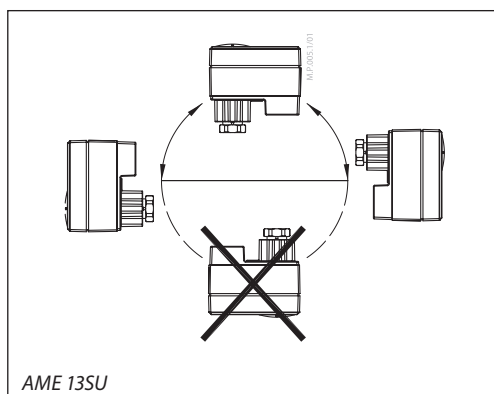

**Mechanical**

The actuator should be mounted with the valve stem in either horizontal position or pointing upwards.

The actuator is fixed to the valve body by means of a mounting nut which requires 32 mm screw key. The nut should be tightened with a torque of max. 6 Nm/53 in-lb, when used with AB-QM.

**Electrical**

Electrical connections can be accessed by removing the cover.

Two M16×1.5 cable entries are provided. However, in order to maintain the enclosure IP rating an appropriate cable gland must be used.

DIP switch setting

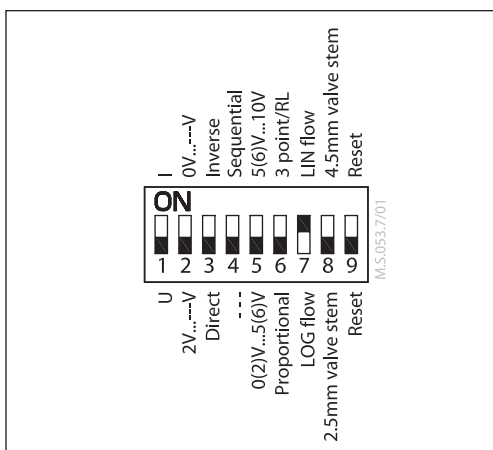

The actuator has a function selection DIP switch under the removable cover. The switch provides the following functions:

- **SW1: U/I** - Input signal type selector:  
If set to OFF position, voltage input is selected.  
If set to ON position, current input is selected.
- **SW2: 0/2** - Input signal range selector:  
If set to OFF position, the input signal is in the range from 2-10 V (voltage input) or from 4-20 mA (current input).  
If set to ON position, the input signal is in the range from 0-10 V (voltage input) or from 0-20 mA (current input).
- **SW3: D/I** - Direct or inverse acting selector:  
If set to OFF position, the actuator is direct acting (stem retracts as voltage increases).  
If the actuator is set to ON position, the actuator is inverse acting (stem extends as voltage increases).
- **SW4: —/Seq** - Normal or sequential mode selector:  
If set to OFF position, the actuator is working normally in 0(2)-10V or 0(4)-20mA range.  
If set to ON position, the actuator is working in a sequential mode with its range dependent on the position of SW 4.

- **SW5: 0-5 V/5-10 V** - Input signal range in sequential mode:  
If set to OFF position, the actuator is working in sequential range 0(2)-5 (6) V or 0(4)-10 (12) mA.  
If set to ON position, the actuator is working in sequential range; 5(6)-10 V or 10(12)-20 mA

- **SW6: Proportional/Floating point** - Modulating or 3-point mode selector:  
If set to ON position, the actuator can operate as Floating point actuator. Power supply should be connected on SN and SP ports. On port 1 or 3 24 VAC signal is connected for rising or lowering of actuator. Return signal X indicates the correct position.  
If set to OFF position, the actuator operates on modulating input signal.

- **SW7: LOG/LIN** - Linear or equal percentage flow through valve selector:  
If set to ON position, the flow through the valve is linear to the control signal.  
If set to OFF position, the valve position is equal percentage acc. to the control signal.  
Note:  
It is generally recommended to configure the AME 13 actuator for operation in linear mode (SW7 set to ON).

- **SW8:**  
Set ON that actuator will modulate on max stem travel of 4.5mm (1/2" to 1-1/4" HF AB-QMs previous generations and AB-QM 4.0 valve versions).  
Set to OFF for valve body 1/2" Low flow. The actuator will modulate on max stem travel of 2.5mm.

- **SW9: Reset:**  
Toggling the switch will cause the actuator to go through an auto-calibration cycle.

**Function test**  
The indicator light shows whether the positioner is in operation or not. Moreover, the indicator shows the control status and faults.

Constant light

- normal operation

No light

- no operation or no power supply

Intermittent light (1 Hz)

- self adjusting-mode

Intermittent light (3 Hz):

- power supply too low
- insufficient valve stroke (<20 s)
- end-position cannot be reached.

Wiring



24 VAC

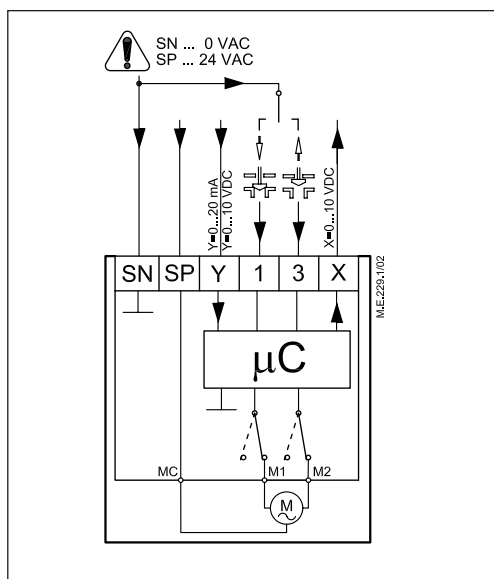

Wiring length	Recommended square of the wiring
0-50 m	0.75 mm <sup>2</sup>
> 50 m	1.5 mm <sup>2</sup>

SP	24 Vac.....Power supply
SN	0 V .....Common
Y	0-10 V .....Input signal (2-10 V) 0-20 mA (4-20 mA)
X	0-10 V .....Output signal (2-10 V)

**Automatic calibrate feature**

When power is first applied, the actuator will automatically adjust to the length of the valve stroke. Subsequently, the self stroking feature can be re-initialised by changing position of DIP SW9.

**Diagnostic LED**

The red diagnostic LED is located on the pcb under the cover. It provides indication of three operational states: Actuator Healthy (Permanently ON), Self Stroking (Flashes once per second), Error (Flashes 3 times per second - seek technical assistance).

**Commissioning**

Complete the mechanical and electrical installation and perform the necessary checks and tests:

- Isolate control medium. (e.g. calibrate in a steam application without suitable mechanical isolation could cause a hazard).
- Apply the power. Note that the actuator will now perform the self stroking function.
- Apply the appropriate control signal and check the valve stem direction is correct for the application.
- Ensure that the actuator drives the valve over its full stroke, by applying the appropriate control signal. This action will set the valve stroke length.

The unit is now fully commissioned.

**Commissioning/testing feature**

The actuator can be driven to the fully open or closed positions (depending on valve type) by connecting SN to terminals 1 or 3.

**Manual override**

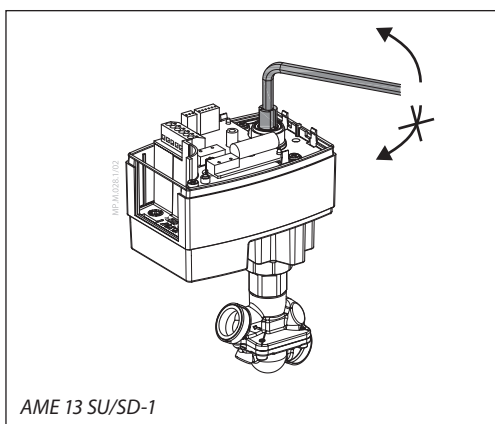

On spring versions manual override is achieved by disconnecting the power supply, removing the cover and inserting a 6 mm Allen key (not supplied) for AME 13 SU/SD-1, into the top of the positioning spindle and turning the key against the spring. Observe the direction of rotation symbol. To hold a manual override position, the key must be wedged.

**If manual override has been used then X and Y signal are not correct until the actuator reaches its end position. If this is not accepted reset the actuator.**

**Safety function**

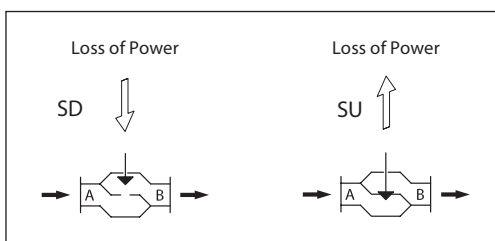

The safety function will fully open or close the valve when the power is removed, depending upon the spring action selected. Valve selection will also affect the spring action. The safety function unit is factory fitted to the rear of the actuator.

**Dimensions**

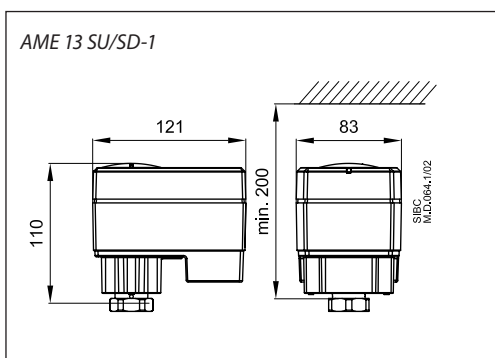



**Danfoss A/S**

Climate Solutions • danfoss.com • +45 7488 2222

Any information, including, but not limited to information on selection of product, its application or use, product design, weight, dimensions, capacity or any other technical data in product manuals, catalogues descriptions, advertisements, etc. and whether made available in writing, orally, electronically, online or via download, shall be considered informative, and is only binding if and to the extent, explicit reference is made in a quotation or order confirmation. Danfoss cannot accept any responsibility for possible errors in catalogues, brochures, videos and other material. Danfoss reserves the right to alter its products without notice. This also applies to products ordered but not delivered provided that such alterations can be made without changes to form, fit or function of the product.

All trademarks in this material are property of Danfoss A/S or Danfoss group companies. Danfoss and the Danfoss logo are trademarks of Danfoss A/S. All rights reserved.