

D140

Bronze Swing Check Valve with Resilient Disc



PN25

D140



Features & Benefits

- Check valves permit flow in one direction only and close automatically if flow reverses
- Entirely automatic in action, depending upon pressure and velocity of flow within the line to perform their functions of opening and closing
- Nitrile rubber disc to give superior seal
- This valve carries the British Standards Institution kitemark
- Conforms with BS 5154:1991 and generally conforms with MSS SP 80.

Materials

NO.	MATERIAL	SIZES
Body	Bronze BS EN 1982 CC491K	All
Cap	Bronze BS EN 1982 CC491K	All
Disc Holder	Brass BS EN 12164 CW614N	1/2 - 1
Disc Holder	Brass BS EN 1982 CW617N	1 1/4 - 2
Disc Holder	Bronze BS EN 1982 CC491K	1/2 - 1 / 2-3
Disc	Nitrile Rubber	All
Disc Retaining Nut	Brass BS EN 12164 CW614N	1/2 - 2 1/2
Disc Retaining Nut	Bronze BS EN 1982 CC491K	3" only
Washer	Brass BS EN 12164 CW614N	1/2 - 2 1/2
Hinge	Bronze BS EN 1982 CC491K	2 1/2 - 3
Hinge	Brass BS EN 1982 CW617N	1/2 - 2
Hinge Pin	Stainless Steel	1/2 - 2
Hinge Pin	Brass BS EN 12164 CW614N	2 1/2 & 3
Hinge Pin Plug	Brass BS EN 12164 CW614N	2 1/2 & 3
Hinge Nut	Brass BS EN 12164 CW614N	All
ID Plate	Aluminium	All
Drive Pin	Steel-Electro Brass	All

Dimensional Drawing

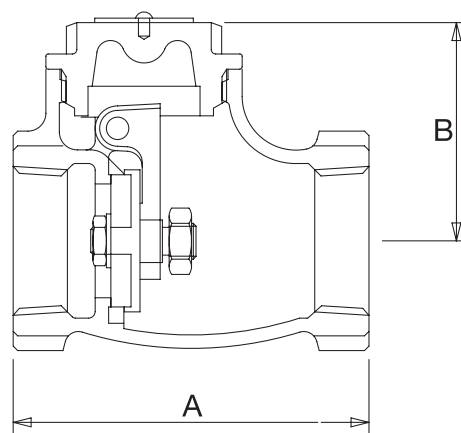

Dimensions & Weights

SIZE (inch)	WEIGHT (kg)	A (mm)	B (mm)
1/2	0.33	58	38
3/4	0.43	66	42
1	0.63	80	49
1 1/4	1.01	89	56
1 1/2	1.34	95	65
2	2.12	108	76
2 1/2	4.2	153	98
3	6.02	188	98

Pressure/Temperature Ratings

TEMPERATURE (°C)	-10 to 100
PRESSURE (BAR)	25

Intermediate pressure ratings shall be determined by interpolation.

PRESSURE RATING: PN25

TEMPERATURE OPERATING RANGE: -10 To 100°C

UK END CONNECTION: Taper threaded to BS EN 10226-2 (ISO 7-1) formerly BS 21

US END CONNECTION: ANSI B1.20.1 (please add suffix AT to denote American Thread)

OPERATOR: Swing Type Check Valve

SPECIFICATION: Bronze Swing Check Valve, Screwed Cap, in accordance with BS 5154:1991, PN25 rated. Valve Body, Cap and hinge to Bronze to BS EN 1982 CC491K. Nitrile Rubber coated Brass and Bronze disc. BSI Kitemark approved.

MSS SP80 CONFORMANCE: D140 complies with MSS SP 80, however, valve markings and threaded ends confirms with BS EN 12288:2010 only. D140.AT complies with threaded ends as well. The Valve is suitable for use in group 2 gases, group 1 and group 2 liquids, as defined by the Pressure Equipment Directive 2014/68/EU.*

*see Quality Assurance page for more information