

# F624

## Fully-Lugged Lever Operated Butterfly Valves



F624

PN16

### Features & Benefits

- WRAS approved for potable water applications -10 to 80°C
- Robust, ductile iron valve body for long life service
- Valve body fully-lugged to fit PN16
- The anti-blow out stem design provides a safe and secure operation
- Integrated notch plate for a more compact design and aluminium lever to reduce risk of corrosion
- Fully bonded epoxy paint system for superior corrosion resistance
- Suitable for applications where Level 3 C3 (Medium) corrosion protection is required
- Maintenance free valve design, reducing downtime
- Suitable for a wide temperature range -10°C to 100°C

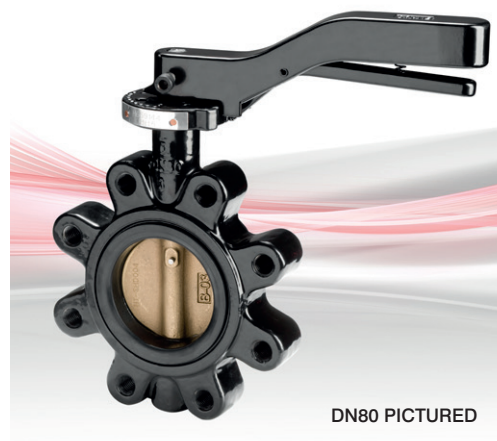

GENERAL VALVES

### Materials

PART	MATERIAL
Body	Ductile Iron ASTM A536 65-45-12 / EN-GJS-450-10 (Epoxy Paint)
Disc	Aluminium Bronze C954 ASTM B148
Liner	EPDM (WRAS Approved) Temp. -10 to 100°C (80°C WRAS)
Shaft	Stainless Steel Type 410
Taper Pin	Stainless Steel Type 410
O-Ring	Buna-N
Bushing	PTFE
Lever	Aluminium Alloy (Epoxy Paint)
Stop Plate	Carbon Steel (Zn Plated)

### Dimensional Drawing

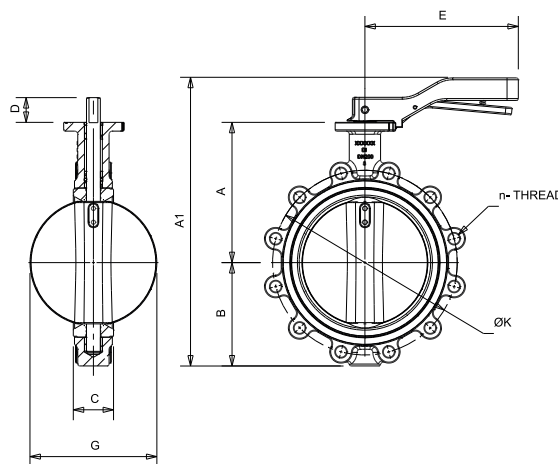

### Dimensions & Weights

SIZE (mm)	WEIGHT (kg)	A (mm)	A1 (mm)	B (mm)	C (mm)	D (mm)	E (mm)	G (mm)	K (mm)	Kv	N- THREAD
50	3.6	109	246	72	43	32	212.5	52.9	125	98	4- M16x2.0
65	4.1	131.5	278.5	82	46	32	212.5	64.6	145	167	4- M16x2.0
80	5.0	134	294	90	46	32	212.5	79	160	258	8- M16x2.0
100	6.5	163	343	108	52	32	212.5	104.4	180	512	8- M16x2.0
125	9.3	169	359	125	56	32	212.5	123.5	210	872	8- M16x2.0
150	11.5	179	392	142	56	40	245	155.8	240	1,347	8-M20x2.5
200	16.8	224	465	165	60	40	378	202.7	295	2,675	12- M20x2.5

### Pressure/Temperature Ratings

	F624
MAX TEMPERATURE (°C)	-10 to 100
PRESSURE (BAR)	16

Intermediate pressure ratings shall be determined by interpolation. WRAS approved -10 to 80°C

\*Kv coefficient denotes valves in fully open position

**PRESSURE RATING:** PN16

**TEST PRESSURES:**

Shell: 24 Bar Seat: 17.6 Bar

**SPECIFICATION:** Butterfly Valve, as per BS EN 593 / ASTM 609 A, Fully Lugged as per BS EN 558, Concentric design, EPDM liner, Fusion Bonded Epoxy paint, Lever operated with integral notch plate and lockable positions. Ductile Iron Body, Al-Brz disc, SS shaft, PN16 rated, suitable to mount between EN 1092-2 PN16 flanges. WRAS Approved for potable water applications.

**MEDIUM:**

Suitable for Group 2 liquids as defined by the Pressure Equipment Directive 2014/68/EU\* WRAS approved valves.

\*see Quality Assurance page for more information

Valid as of 21/02/24

Every effort has been made to ensure that the information contained in this publication is accurate at the time of publishing. Crane Ltd assumes no responsibility or liability for typographical errors or omissions or for any misinterpretation of the information within the publication and reserves the right to change without notice.