

F648G / F644G / F658G / F654G / F678G / F674G

Fully Lugged Gearbox Operated Butterfly Valves

PN16



Features & Benefits

- Valves are suitable for use with flanges conforming to BS EN 1092-2 PN16
- Valve to BS EN593
- Ductile Iron, Stainless Steel, Aluminium Bronze Disc Options
- EPDM and Nitrile Seat Liner Options
- 420 Stainless Steel Shafts for superior strength

Materials

PART	MATERIAL
Body	Ductile Iron (EN-GJS-400-15)
Disc (F648G & (F644G) (DN150-600)	Ductile Iron (EN-GJS-400-15) Epoxy Coated
Disc (F658G & F654G) (DN150-600)	Stainless Steel 304 (ASTM A351 CF8)
Disc (F678G & F674G) (DN50-600)	Aluminium Bronze (ASTM B148 C95400)
Liner (F648G, F658G & F678G)	EPDM
Liner (F644G, F654G & F674G)	Nitrile rubber
Shaft	Stainless Steel 420 (ASTM A276 420)
Taper Pin	Stainless Steel 431 (ASTM A276 431)
O-Ring	Nitrile rubber
Bushing	PTFE

Dimensions & Weights

SIZE (mm)	WEIGHT (kg)			H2	H1	L	H	L1	ØE	DD	Kv
	BARESHAF	GEARBOX									
50	3.0	7.9		141	61	43	32	157	52.9	145	133
65	3.4	8.3		153	72	46	32	157	64.7	145	227
80	4.7	9.6		161	87	46	32	157	79.1	145	349
100	6.6	11.5		179	106	52	32	157	104.4	145	694
125	9.1	14.0		193	123	56	32	157	123.3	145	1181
150	10.0	14.9		204	137	56	32	157	155.6	145	1825
200	17.4	26.2		247	174	60	45	236	202.5	300	2503
250	25.0	34.0		280	209	68	45	236	250.5	300	3876
300	34.0	46.0		324	253	78	45	237	301.6	300	6736
350	52.0	63.0		310	260	78	48	237	333.6	300	8135
400	81.0	106.0		340	317.5	102	64	246	389.5	300	12041
450	106.0	131.0		375	330	114	64	246	440.5	380	14121
500	140.0	170.0		425	367	127	64	254	489.7	285	18449
600	220.0	270.0		505	443	154	82	301	592.7	400	24125

Valve Selection

	EPDM LINER	NITRILE LINER
DUCTILE IRON DISC	F648G	F644G
STAINLESS STEEL DISC	F658G	F654G
ALUMINIUM BRONZE DISC	F678G	F674G

Dimensional Drawing

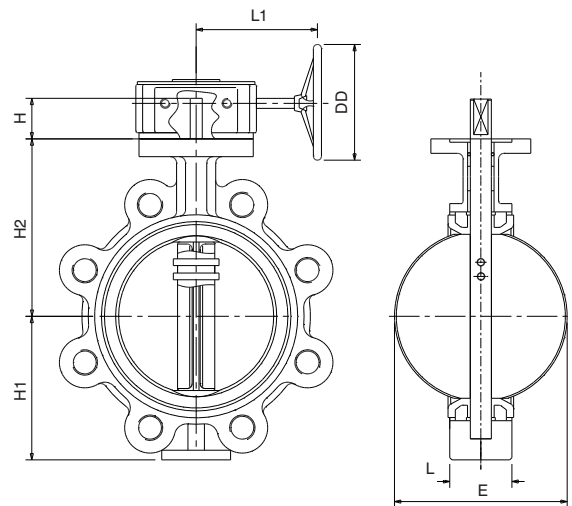

Pressure/Temperature Ratings

	F648G / F658G / F678G	F644G / F654G / F674G
TEMPERATURE (°C)	-10 to 120	-10 to 82
PRESSURE (BAR)	16	16

PRESSURE RATING: PN16

END CONNECTION: Fully Lugged

OPERATOR: Gearbox

OTHER: Bare shaft options available

(Fig No. F648B / F644B / F658B / F654B / F678B / F674B)

Please contact us for bare shaft top works details

SPECIFICATION: End connections compatible with BS EN1092-2 PN16 flanges.

TEST PRESSURES: (Hydrostatic)

SHELL: 24 bar

SEAT: 17.6 bar

Valid as of 08/2020

Every effort has been made to ensure that the information contained in this publication is accurate at the time of publishing. Crane Ltd assumes no responsibility or liability for typographical errors or omissions or for any misinterpretation of the information within the publication and reserves the right to change without notice.