

# FA648L / FA644L / FA658L / FA654L / FA678L / FA674L

Fully Lugged Lever Operated  
Butterfly Valves

ANSI 125

FA648L



GENERAL VALVES

## Features & Benefits

- Valves are suitable for use with flanges conforming to ANSI B16.1 Class 125
- Valve generally conforms to MSS SP 67
- Ductile Iron, Stainless Steel, Aluminium Bronze Disc Options
- EPDM and Nitrile Seat Liner Options
- 420 Stainless Steel Shafts for superior strength

## Materials

PART	MATERIAL
Body	Ductile Iron (EN-GJS-400-15)
Disc (FA648L & FA644L) (2"-8")	Ductile Iron (EN-GJS-400-15) Epoxy Coated
Disc (FA658L & FA654L) (2"-8")	Stainless Steel 304 (ASTM A351 CF8)
Disc (FA678L & FA674L) (2"-8")	Aluminium Bronze (ASTM B148 C95400)
Liner (FA648L, FA658L & FA678L)	EPDM
Liner (FA644L, FA654L & FA674L)	Nitrile rubber
Shaft	Stainless Steel 420 (ASTM A276 420)
Taper Pin	Stainless Steel 431 (ASTM A276 431)
O-Ring	Nitrile rubber
Bushing	PTFE
Lever & Screw	Malleable Iron ASTM Gr.32510
Stop Plate	Mild Steel (GB700 Q235) Chromium Plated

## Valve Selection

	EPDM LINER	NITRILE LINER
DUCTILE IRON DISC	FA648L	FA644L
STAINLESS STEEL DISC	FA658L	FA654L
ALUMINIUM BRONZE DISC	FA678L	FA674L

## Dimensional Drawing

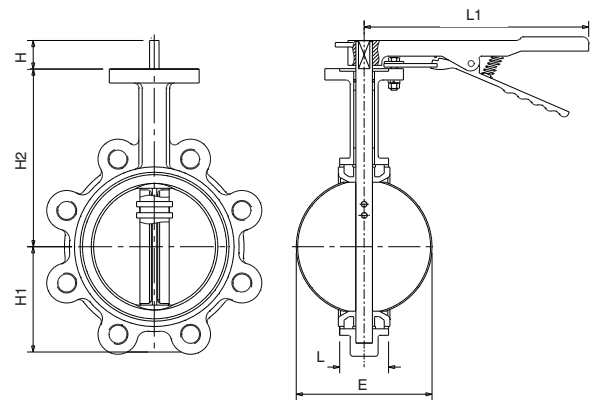

## Dimensions & Weights

SIZE (inch)	WEIGHT (kg)	H2	H1	L	H	L1	ØE	Kv
2	3.5	141	61	43	32	216	52.9	133
2 1/2	3.9	153	72	46	32	216	64.7	227
3	5.2	161	87	46	32	216	79.1	349
4	7.3	179	106	52	32	265	104.4	694
5	9.8	193	123	56	32	265	123.3	1181
6	10.7	204	137	56	32	265	155.6	1825
8	18.3	247	174	60	45	374	202.5	2503

## Pressure/Temperature Ratings

	FA648L / FA658L / FA678L	FA644L / FA654L / FA674L
TEMPERATURE (°C)	-10 to 120	-10 to 82
PRESSURE (BAR)	16	16

**PRESSURE RATING:** ANSI 125

**END CONNECTION:** Fully Lugged

**OPERATOR:** Trigger Lever

**OTHER:** Bare shaft options available

(Fig No. FA648B / FA658B / FA644B / FA654B / FA678B / FA674B)

Please contact us for bare shaft top works details

**SPECIFICATION:** End connections compatible with ANSI B16.1 Class 125 flanges.

**TEST PRESSURES:** (Hydrostatic)

**SHELL:** 24 bar

**SEAT:** 17.6 bar

Valid as of 08/12/20

Every effort has been made to ensure that the information contained in this publication is accurate at the time of publishing. Crane Ltd assumes no responsibility or liability for typographical errors or omissions or for any misinterpretation of the information within the publication and reserves the right to change without notice.