

FA700 / FA701 & FA700B

26" – 56"

PN16
PN10

FA700



GENERAL VALVES

Features & Benefits

- Suitable for Gearbox or Actuator operation
- Rugged construction: Ductile Iron Body for all sizes
- Stainless Steel disc as standard
- Epoxy paint coated as standard
- Low operating torques
- ANSI flange and hole pattern

Materials

NO.	PART	MATERIAL	SPECIFICATION
1	Key	Carbon Steel	ASTM A29 1045
2	Screw	Carbon Steel	ASTM A194 Gr.2H
3	Short Bushing	-	PTFE
4	O' Ring	-	NBR
5	Upper Shaft	Stainless Steel	ASTM A276 420
6	Body	Ductile Iron	EN-GJS-500-7U
7	Long Bushing	-	PTFE
8	Seat + Backing Ring	-	EPDM + Aluminium
9	Disc: FA700/FA700B	Stainless Steel 316	ASTM A351 CF8M
	Disc: FA701	Stainless Steel 304	ASTM A351 CF8
10	Pin	Stainless Steel	ASTM A276 431
11	Lower Shaft	Stainless Steel	ASTM A276 420
12	Split Retaining Ring	Carbon Steel	ASTM A29-1045
13	Bearing	High Carbon Steel	ASTM A295 52100
14	Screw	Carbon Steel	ASTM A194 Gr. 2H
15	Lower Gland	Carbon Steel	EN-GJS-500-7U
16	Gearbox	Ductile Iron	EN-GJS-400-15

Dimensional Drawing

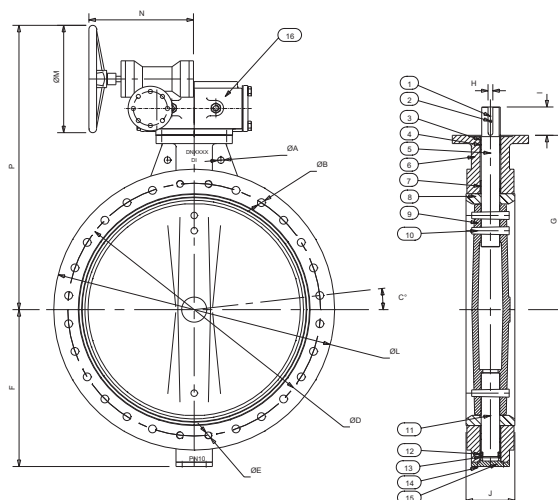

Dimensions & Weights

SIZE (inch)	A (mm)	B (mm)	C (mm)	D (mm)	E (mm)	F (mm)	G (mm)	H (mm)	I (mm)	J (mm)	K (mm)	L (mm)	M (mm)	N (mm)	P (mm)	FLANGE THICKNESS	WEIGHT (kg)		FLOW (kv)
																	Gearbox	Bareshaft	
26"	N/A	20-Ø35	7.5	806.5	4-1.25-7	485	565	14	110	165	N/A	870	600	346	913	39.5	307	270	37300
28"	N/A	24-Ø35	6.43	863.6	4-1.25-7	537	629	18	110	165	4-Ø40	927	398	397	883	39.5	380	340	42818
30"	N/A	24-Ø35	6.43	914.4	4-1.25-7	565	660	18	110	165	4-Ø40	984	500	417	965	43	410	370	63513
32"	N/A	24-Ø41	6.43	977.9	4-1.5-6	596	666	20	110	190	4-Ø40	1060	500	417	971	43	490	450	33086
34"	N/A	28-Ø41	5.625	1028.7	4-1.5-6	633	720	20	110	200	4-Ø40	1111	500	450	1032	45	585	530	52300
36"	N/A	28-Ø41	5.625	1085.9	4-1.5-6	656	720	20	110	203	4-Ø42	1168	500	450	1032	46.5	665	610	75688
38"	N/A	28-Ø41	5.625	1149.4	4-1.5-6	675	708	22	110	200	4-Ø44	1238	600	450	1070	50	745	690	91500
40"	2-Ø40	32-Ø41	5	1200.1	4-1.5-6	720	800	22	130	216	4-Ø45	1289	500	470	1109	50	830	760	103584
42"	N/A	32-Ø41	5	1257.3	4-1.5-6	772	850	22	130	251	4-Ø47	1346	500	470	1159	53.5	1070	1000	101638
48"	2-Ø46	40-Ø41	4.1	1422.4	4-1.5-6	864	942	28	130	254	N/A	1511	600	491	1327	57	1300	1160	133210
56"	2-Ø48	44-Ø47.8	3.75	1651	4-1.75-5	1014	1000	40	180	279	N/A	1746	600	491	1385	46	1676	1550	152700

PRESSURE RATING: 26" - 56" ANSI CLASS 150

TEMPERATURE RATING: -20°C to 120°C

FACE TO FACE DIMENSIONS: BS EN 558: 2011 Series 20

END CONNECTIONS: ASME B16.47A

ACTUATOR MOUNTING FLANGES: ISO 5211: 2001

OPERATORS: Gearbox - FA700 (Disc SS 316) / FA701 (Disc SS 304)

BARESHAF VALVE OPTIONS: FA700B

MEDIUM: Manufactured to BS EN 593: 2009. Complies with Pressure Equipment Directive 2014/68/EU. Equipment Directive 2014/68/EU.

Valid as of 14/09/21

Every effort has been made to ensure that the information contained in this publication is accurate at the time of publishing. Crane Ltd assumes no responsibility or liability for typographical errors or omissions or for any misinterpretation of the information within the publication and reserves the right to change without notice.