

FM463 / FM466 / FA463

Double Door Check Valves

PN16 / PN25 / ANSI125

FM463



Features & Benefits

- Check valves permit flow in one direction only and close automatically if flow reverses, depending upon pressure and velocity of flow to perform the functions of the opening and closing.
- Non-Slam design as a result of rubber seat and spring-assisted closure.
- EPDM rubber seat to facilitate quiet operation and improve disk seating.
- Eyebolt tapped holes in sizes DN200 and above, to fit bolts to BS EN ISO 3226:2010 (eyebolts are not supplied with product).
- Design and construction lends itself to pump duty applications.

Materials

NO.	PART	MATERIAL
1	Body	Cast Iron EN-GJL-250 PN16/ANSI125 DN50-DN150
		Ductile Iron EN-GJS-400-15 PN16/ANSI125 DN200-DN600
		Ductile Iron EN-GJS-400-15 PN25 DN50-DN600
2	Disc	Stainless Steel SS304
3	ID Plate	Anodised Aluminium
4	Seat	EPDM Max 120°C
5	Stop Bolt	Stainless Steel 304
6	Stem	Stainless Steel 304
7	Spring	Stainless Steel 304
8	Washer	PTFE
9	Gasket	EPDM Max 120°C

Dimensional Drawing

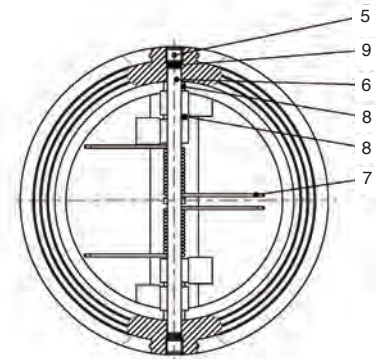
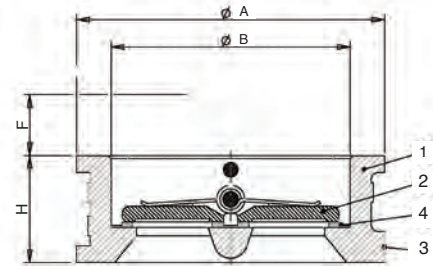

Dimensions & Weights

SIZE	A (mm)		B (mm)	F (mm)	H (mm)	WEIGHT (Kg)	EYEBOLT TAPPING (To BS EN 3226:2010)	Kv VALUES
	PN16	ANSI 125						
DN50	107	102	66.0	10.0	43.0	1.5	N/A	44
DN65	127	121	80.5	16.0	46.0	2.2	N/A	102
DN80	142	133	95.0	15.0	64.0	3.2	N/A	128
DN100	162	171	119.0	28.0	64.0	4.1	N/A	203
DN125	192	193	146.0	38.0	70.0	5.7	N/A	528
DN150	218	219	171.0	47.0	76.0	8.2	N/A	688
DN200	273	276	224.5	70.0	89.0	14.6	M8	1315
DN250	328	336	266.0	78.0	114.0	24.2	M10	2315
DN300	382	406	311.0	104.0	114.0	35.8	M10	3623
DN350	442	448	360.0	127.0	127.0	54.0	M12	4620
DN400	495	511	410.0	143.0	140.0	76.0	M12	5166
DN450	555	546	450.0	158.0	152.0	103.0	M16	6164
DN500	617	603	505.0	183.0	152.0	126.0	M16	9670
DN600	734	714	624.0	221.0	178.0	187.0	M16	15340

Selection

FIG NO.	FM463	FM466	FA463
PRESSURE RATING	PN16	PN25	ANSI125

PRESSURE RATING: FM463: PN16, FA463: ANSI 125, FM466: PN25

TEMPERATURE OPERATING RANGE: -10 to 120°C

UK END CONNECTION: Suitable for flange connection to BS EN 1092-2 PN16 / BS EN 1092-2 PN25

US END CONNECTION: BS 1560, ANSI B16.1, ANSI B16.5

SPECIFICATION: Designed in accordance with BS EN 16767. Face-to-face dimensions conform to BS EN 558 series 16. Suitable for installation in vertical and horizontal pipelines.

When installed in vertical pipelines the flow must be in an upward direction.

This valve is suitable for use on Group 2 liquids only, as defined by the Pressure Equipment Directive 2014/68/EU.*

* See page 159 for more information

Valid as of 08/12/20

Every effort has been made to ensure that the information contained in this publication is accurate at the time of publishing. Crane Ltd assumes no responsibility or liability for typographical errors or omissions or for any misinterpretation of the information within the publication and reserves the right to change without notice.